

Some Review Problems from Chapters 1 – 12

2) The two masses shown in the figure below are each initially 1.80 m above the ground, and the massless frictionless pulley is fixed 4.8 m above the ground. What maximum height does the lighter object reach after the system is released?

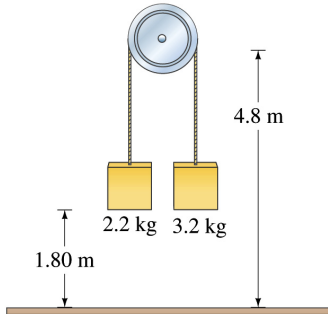

3) An 8.00 g bullet is fired into a 2.50 kg block initially at rest at the edge of a frictionless table of height 1.00 m (see the figure below). The bullet remains in the block, and after impact the block lands 2.00 m from the bottom of the table. Determine the initial speed of the bullet.

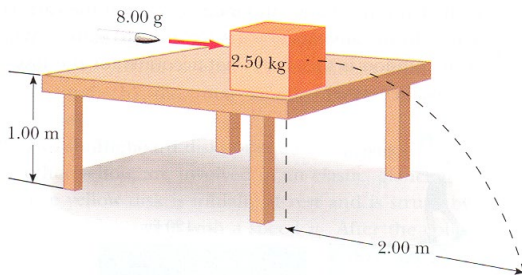

4) The system in the figure below is released from rest. The 30-kg block is 2 m above the ledge. The pulley is a uniform disk with a radius of 10 cm and mass of 5 kg. Find (a) the speed of the 30 kg block just before it hits the ledge, (b) the angular speed of the pulley at the time, (c) the tension in the strings, and (d) the time it takes for the 30 kg block to reach the ledge. Assume that the string does not slip on the pulley.

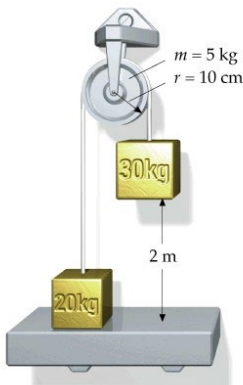

5) In a physics lab, a small cube slides down a frictionless incline as shown in the figure below, and elastically strikes a cube that is only one-half its mass. If the incline is 20 cm high and the table is 90 cm off the floor, where does each cube land?

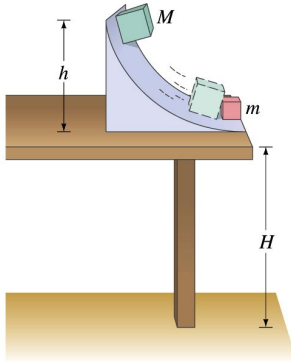

7) A solid steel ball of mass 0.50 kg and diameter 20 cm is held in place against a spring with spring constant $k = 250 \text{ N/m}$, compressing the spring a distance $x = 20 \text{ cm}$. The ball is then released from rest and rolls without slipping along a horizontal floor. It then makes a smooth transition to an inclined plane and rolls without slipping up a 0.60 m high inclined plane as shown in the figure below.

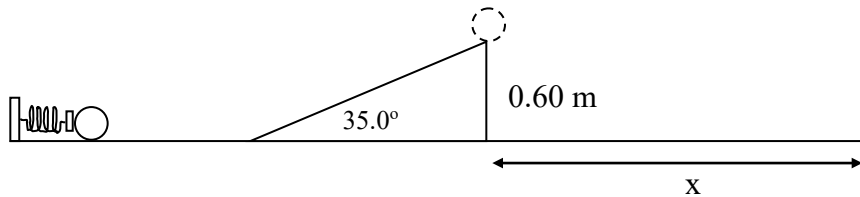

a) What is the speed of the ball just as it leaves the inclined plane?

b) How far from the inclined plane (i.e. what is x in the figure) will the ball land?