

Celebration #2: Circuits and Magnetism

Short Answer Questions (28 points total)

Question 1 (6 points)

Determine the direction of \mathbf{B} for each case in the figure below, where \mathbf{F} represents the force on *an electron* moving with velocity \mathbf{v} .

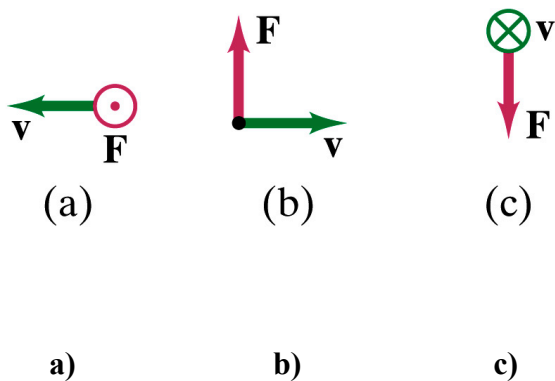

Question 2 (6 points)

Two incandescent lamps are connected in series to a battery. The lamps are not identical: lamp A has a filament (i.e. the wire through which current flows) that is shorter and has a larger cross-sectional area than the filament in lamp B. Both filaments are made of tungsten.

For each of the following variables, indicate whether the value for lamp A is greater than, less than, or the same as the value for lamp B.

(a) resistance

(b) current

(c) voltage drop

(d) power

Question 3 (5 points)

A circuit containing six resistors is connected to a 120 V power supply as shown in the figure below. What is the potential difference between points A and B?

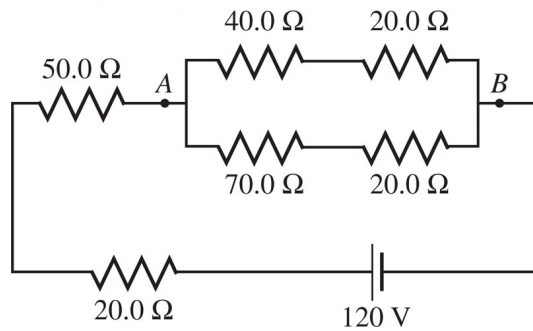

Question 4 (5 points)

A proton moves with a velocity $\vec{v} = (5.5 \text{ m/s})\hat{i} - (7.25 \text{ m/s})\hat{k}$ in a magnetic field given by $\vec{B} = (10.6 \text{ mT})\hat{j} + (9.5 \text{ mT})\hat{k}$. Determine the magnetic force on the proton in unit vector notation.

Question 5 (6 points)

In the circuit below, there are seven possible combinations of R_1 , R_2 , and R_3 . Each value in the table is the resistance in ohms. Rank the seven combinations on the basis of the reading on the voltmeter, from highest to lowest.

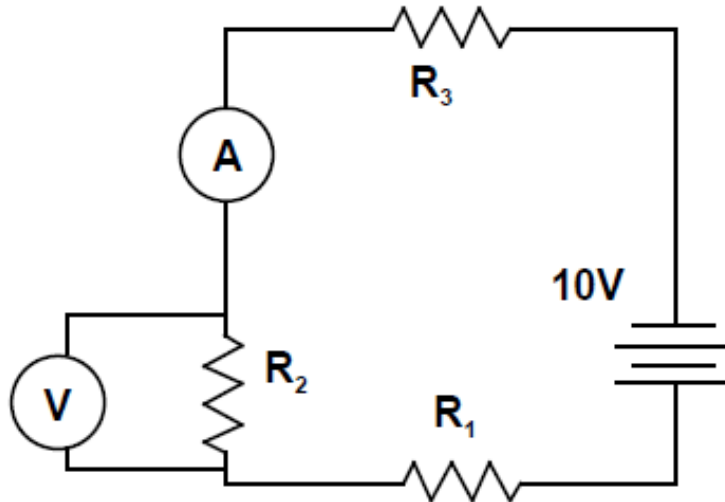

	A	B	C	D	E	F	G
R_1	1	2	3	2	4	1	0
R_2	2	1	2	2	1	1	5
R_3	3	3	1	2	1	4	1

Ranking (2 points):

Highest 1 _____ 2 _____ 3 _____ 4 _____ 5 _____ 6 _____ 7 _____ Lowest

Explanation (1 points):

Explain (in words) your reasoning behind the above ranking.

Calculation (3 points):

What is the reading on the voltmeter in the combination(s) that has the highest ranking? Show your work.

Problems (12 points each)

Problem 1

In the figure below, what is the distance d if the net magnetic field at point P is $8.60 \mu\text{T}$ into the page? (**Note:** the bottom wire is infinitely long.)

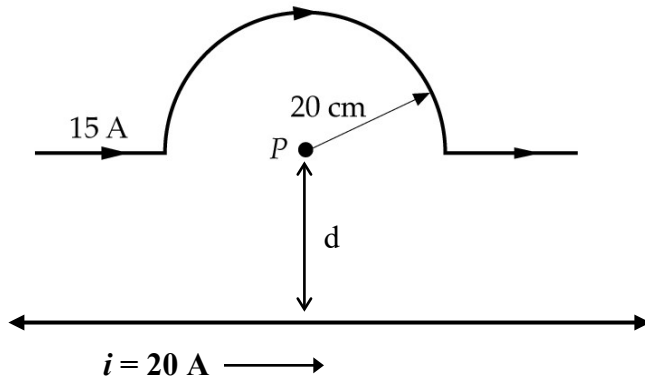

Problem 2

In the circuit below, $R_1 = 25.0\ \Omega$, $R_2 = 20.0\ \Omega$, $R_3 = 25.0\ \Omega$. Use Kirchoff's laws to find the current through and the voltage drop across each resistor. Be sure to label the currents (including assumed directions) and the directions of each loop in the figure below.

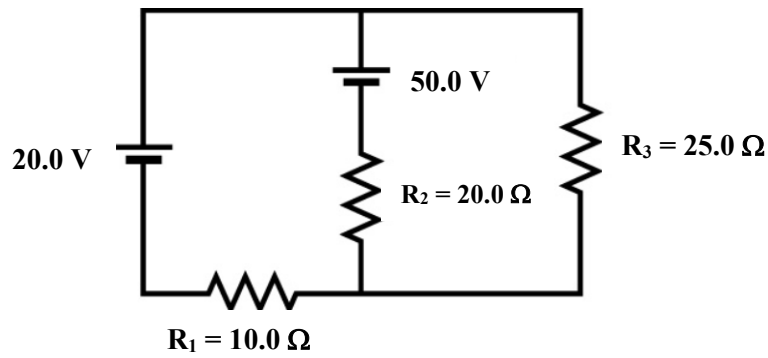

Problem 3

In the circuit below, $R = 720 \, \Omega$ and the capacitor is initially uncharged. The switch is then closed, and after $0.010 \, \text{s}$, the charge on the capacitor has increased to half of its final value. What is the capacitance of the capacitor?

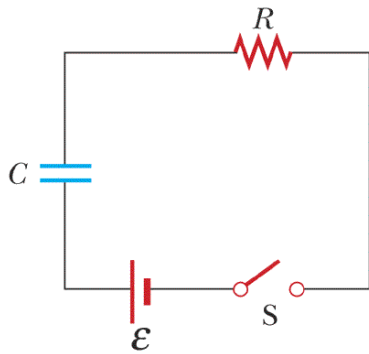

Problem 4

A charge $q = -5.0 \mu\text{C}$ is traveling straight upwards at $7.5 \times 10^5 \text{ m/s}$ when it encounters a region of space which contains uniform electric and magnetic fields. The magnetic field has a magnitude of $2.7 \times 10^{-4} \text{ T}$ and points out of the page. The electric field has a magnitude of $5.7 \times 10^2 \text{ N/C}$ and points straight upwards. What is the magnitude and direction of the net force on the charge once it enters the fields?

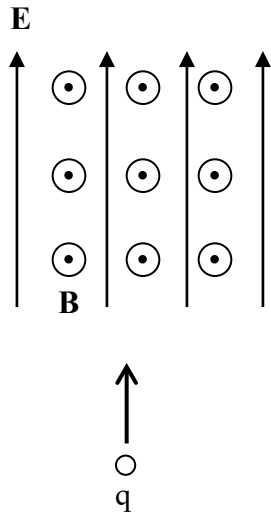

Problem 5

A 5.00 m length of 2.00-millimeter-diameter copper wire has a 25.0 mV potential difference applied across its ends. Copper has a resistivity of $\rho = 1.77 \times 10^{-8} \Omega \cdot \text{m}$ and $8.8 \times 10^{28} \text{ m}^{-3}$ charge carriers per unit volume.

What is **(a)** the current density inside the wire, **(b)** the electric field inside the wire, and **(c)** the drift speed of electrons inside the wire? **(d)** How much energy will be dissipated by the wire as thermal energy in 5.0 minutes?

Problem 6

For the circuit shown in the figure below, find the current through and the potential difference across each resistor. Place your results in the table.

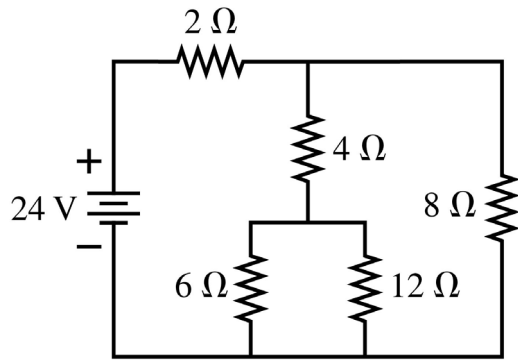

Resistor	Current (A)	Potential difference (V)
2 Ω		
4 Ω		
6 Ω		
8 Ω		
12 Ω		

